

ROLS

BY CHAPUIS ARMES

INSTRUCTION MANUAL

The new straight pull rifles range

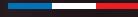

www.chapuis-armes.com

OPERATING INSTRUCTIONS

I)) SAFETY MEASURES	Page 1
II) DESASSEMBLING AND ASSEMBLING	Page 2-3
III) MAGAZINE OPERATIONS	Page 4-5
IV) COCKING DEVICE	Page 6-7
V) LOADING AND FIRING	Page 7
VI) CHANGING CALIBER	Page 8-9
VII) SCOPE MOUNTS	Page 10
VIII) CLEANING AND SERVICING	Page 10
IX) THE MULTI PURPOSE TOOL	Page 11
X) GUARANTEE	Page 12

MAIN PARTS OF THE ROLS® RIFLE

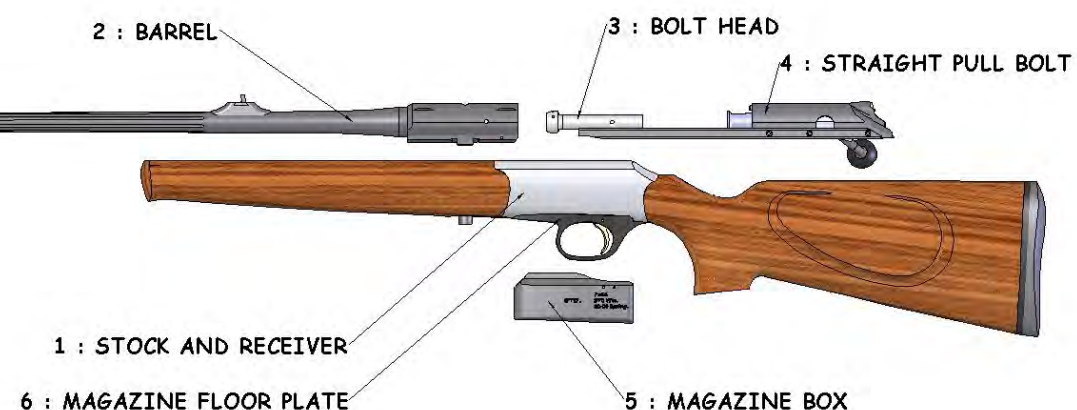

I) SAFETY MEASURES

GUARANTEE DO NOT APPLY FOR THE FOLLOWING REASON

This rifle made in France was tested with ammunition which are in compliance with the international standards set by the CIP.

Proof ammunition have been supplied by the French Official Saint Etienne Proof House. (FRANCE)

Operating and functioning of this rifle are perfect, whenever ammunition used are complying with industrial specifications and manufacturing standards.

The “Société Chapuis Armes” is not liable for any damage or injuries resulting from use of non-standard, faulty, or reloaded ammunition.

C.I.P. = International Commission for Proofing portable weapons

SAFETY MEASURES TO BE READ BEFORE USE

Your rifle should always be considered as loaded and, before any handling, check that it is unloaded by opening the bolt and making sure that no cartridge is in the chamber. Even unloaded, never point the barrel towards anyone, or towards anything, that you actually do not want to shoot at.

Before loading the rifle, inspect the barrel to make sure that nothing is obstructing it: Mud, snow, water, etc. which could lead to an explosion of the barrel, with serious consequences to the shooter or to any bystanders. Your barrel should be free of oil residues so as to prevent a lack of precision. While using your rifle, make sure that nothing has slipped into your barrel.

While using your rifle, always keep your fingers away from the trigger, as long as the sights are not pointing towards the target that you intend to shoot at. You must always perfectly identify the target before shooting, the shooter being always responsible of an accidental discharge or of an intended shot.

The “Société Chapuis Armes” is not liable for any damage or injuries resulting of an accidental discharge or from an intended shot.

II) DISASSEMBLING AND ASSEMBLING THE RIFLE

1) Assembling the barrel on the stock of your rifle:

- Set the barrel into its bedding -2-, as shown on the drawing. This operation can be performed only with an open bolt -1-
- With the supplied Torx-head screw driver, secure the barrel onto the receiver with the screw located underneath -3-. It is not necessary to exert any force beyond blocking point.
- To take off the barrel, pull and open the bolt -1-. With the supplied Torx-head screwdriver completely loosen the screw underneath the receiver. Once this done, simply lift up the barrel while still holding the stock. The barrel is now free.



2) Assembling the bolt assembly on the stock:

- To assemble the bolt assembly on the receiver, you are to position both rails lined up behind the two matching recesses machined on the receiver.
- Once both rails are set into place, press down the button -1- on the left side of the rear of the receiver, your left thumb pressing down the left rail of the bolt assembly, then push the bolt -2- forward.

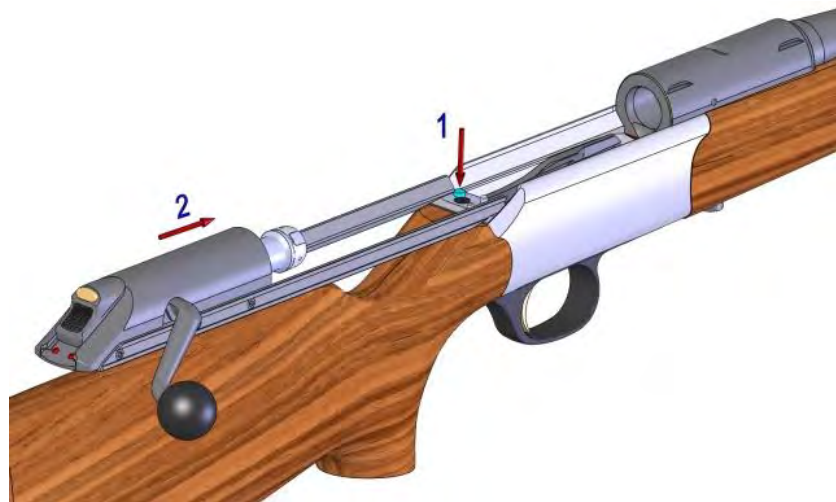

- Push the bolt -3- with the bolt lever -4- until the bolt is locked into the barrel. Whenever these operations are not smooth, do not use extra strength, it simply means that the rails have not been correctly positioned on the receiver.



- To remove the bolt from the receiver, once the magazine has been taken away, pull the bolt -2- until it stops on a release button -1-. Press down the button -1- located on the left side of the receiver and keep it down completely. Then pull the bolt -2- backwards by means of the bolt lever and take the bolt away from the receiver. Once the bolt is taken off the receiver, you can put back the bolt back into place. Make sure that the rails and matching recesses are lined up.

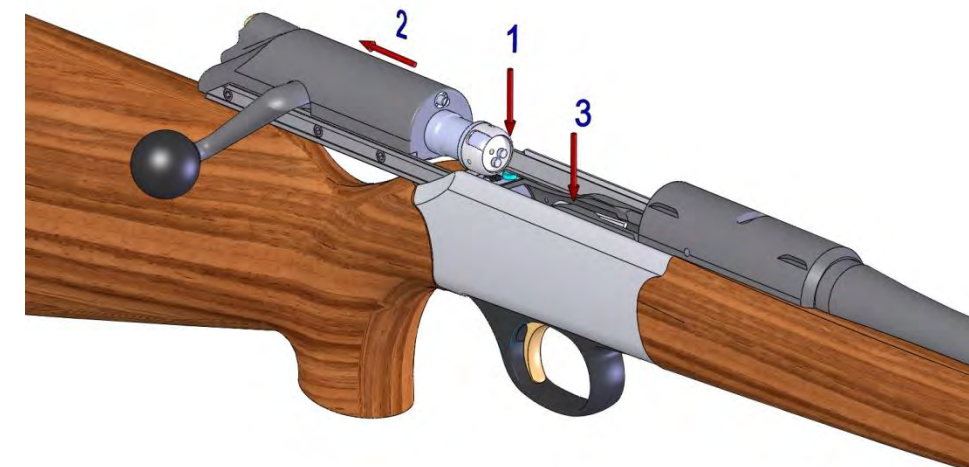

Whenever the magazine is secured into the receiver, a preliminary operation is then required:

First, exert a pressure on the top of the magazine -3- so as to be able to pull back completely the bolt -1-.

WARNING During the assembling of the bolt on the receiver, the hinged magazine floor plate must be closed. If not, you are to close it first, because it is impossible to assemble the bolt on the receiver whenever the magazine floor plate is open.

In case of problem, or if you have a question pertaining to the assembly of the two main parts, please contact our dealer.

II) OPERATING THE DETACHABLE BOX MAGAZINE

- 1) To insert the magazine on your rifle, you are firstly to open the hinged magazine floor plate -2- by pressing down a button under the receiver -1-



- 2) Once the magazine well free, you can insert the magazine box -3-.
- 3) Once it is in place, close and lock the hinged magazine floor plate -4-.



- 4) To remove the magazine, proceed the other way round. Whenever you wish a quick change of magazine, keep a constant pressure on the magazine release button -1- until it drops down.

WARNING When the magazine floor plate is open, it automatically decocks the rifle. Once the magazine box is again secure onto the rifle and the floor plate locked, you have to push back the cocking button in order to shoot the rifle.

- 5) Loading the magazine box can be done in two ways:

- a) Holding the box you can feed the magazine with cartridges, one by one, pushing them from back to front until they are stopped. Once the magazine is filled, apply with your thumb a gentle pressure on the cartridge on the top. The cartridges will thus fit snugly in the magazine, preventing any feeding problem during the quick reloading of your rifle.

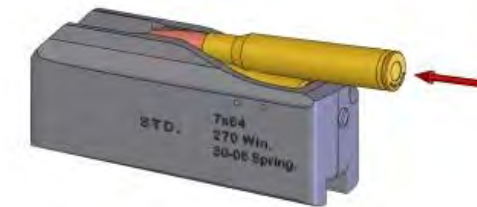

- b) While hunting, you can shoot the first round, then open the bolt assembly and fill the magazine from the top, without taking it away from the receiver.

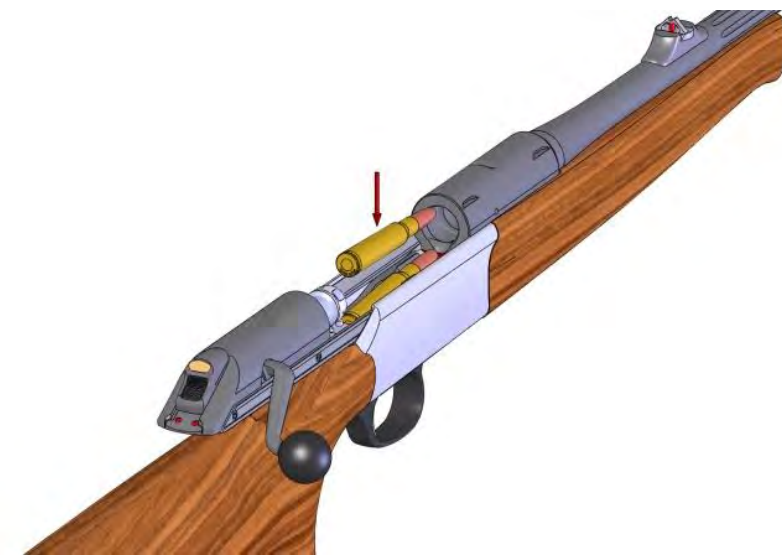

- a) To empty your magazine, you are to remove it from the rifle. Once the magazine box in hand, eject the remaining cartridges by pushing them from back to front.

The magazine bears on the right and on the top a stopping device made of specially hardened steel. It is intended to match the length of travel of the bolt assembly with the length of the cartridges, according to their caliber.

IV) Operating the independent cocking/de-cocking device

- 1) To cock the rifle, firmly press the cocking device with your thumb until it clicks and rests into the cocked position

WARNING During this operation, make sure not to touch the little un-cocking release button on top of the cocking device.



- 2) The rifle is then ready to shoot. 2 red dots are showing behind the cocking device.



- 3) To de-cock your rifle, press the un-cocking release button, located on top of the cocking device. A distinct "click" is heard then the cocking device slides rearwards, the 2 red dots are not showing anymore. The firing pin spring is now decompressed.



WARNING De-cocking the rifle automatically locks the bolt on the barrel. To re-open the bolt, you are first to cock the rifle. (Refer to § IV -1)

- 4) Opening the bolt when rifle is de-cocked. Push slightly the cocking piston one fifth of an inch, keep it in this position, and open the bolt with the bolt lever.

V) LOADING AND FIRING

- 1) Make sure that your magazine is full and secured in the receiver (Refer to § III).
- 2) Open completely the bolt assembly by pulling the bolt lever until it stops.
- 3) Push the bolt lever and close the bolt. It strips a cartridge from the magazine and chambers it. Once the cartridge is in the chamber, you can push down the bolt lever which must come to a vertical position. The rifle is then ready to fire. Just press the trigger.

WARNING Your rifle is equipped with a patented "CLS" (Chapuis Locking System) which prevents the rifle from firing, should the bolt not be completely locked. The bolt is completely locked, only when and if the bolt lever is fully back in the vertical position, as shown hereafter.

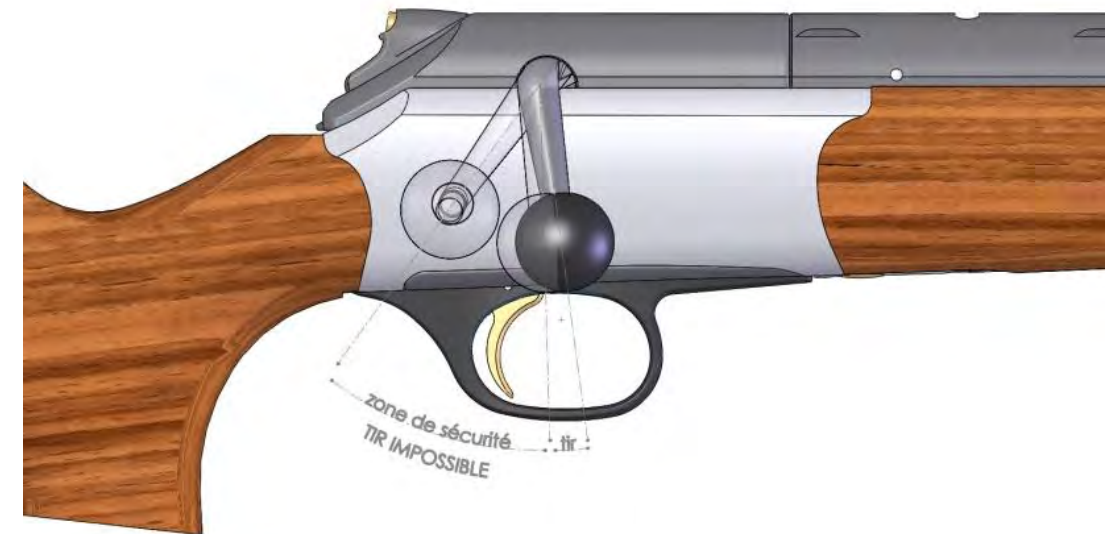

- 4) To eject the spent case, open the bolt by pulling the bolt lever.
- 5) Whenever you close the bolt with a cocked firing pin, 2 red dots showing, the rifle is ready to shoot. If you do not wish to shoot, you are to de-cock the firing pin by depressing the de-cocking release button. (Refer to § IV)

VI) CHANGING CALIBERS

There are two groups of calibers: "Standard" and "Magnum" which are described hereafter :

	Bolt Head		Type of magazine
	Standard	Magnum	
Standard Group			
6,5x55 SE	X		6,5x55 SE
243 Win	X		243Win
308 Win	X		308 Win
7x64	X		7x64
270 Win	X		
30.06	X		
9,3x62	X		9,3x62
Magnum Group			
300Win Mag		X	300 Win
7Rem Mag		X	
375 H&H		X	375 H&H

When changing caliber, make sure that the bolt head, magazine and barrel are matched.

Refer to the above-mentioned table. To avoid any confusion, calibers are fully mentioned on the right side of the barrels and they show, even when assembled on the rifle. On the bolt head, the letters "S" or "M" are engraved on the extractor claw, while on the left side of the magazine box are mentioned the calibers it will accept.

- 1) After opening the bolt, you can change the barrel. (Refer to § II-1-c)
- 2) Changing the bolt head. Remove the bolt assembly (Refer to § II-2-d)
 - a. Turn this axle one half turn anti-clockwise, so as to bring the padlock symbol in front of a bearing engraved on the bolt shaft.
 - b. The bolt head -2- is now free. You can remove it by pulling it.

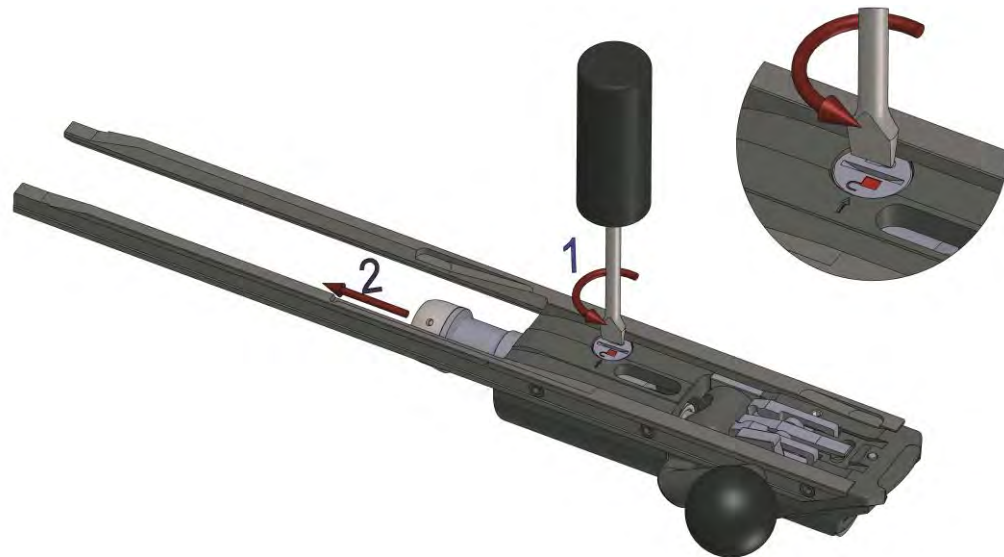

- c. To insert a new bolt head, carefully selecting "Standard" or "Magnum" group, according to the letter "S" or "M" engraved on the extractor claw. Next, you are to insert the bolt head in its housing, while making sure that the firing pin is well positioned inside the new bolt head.

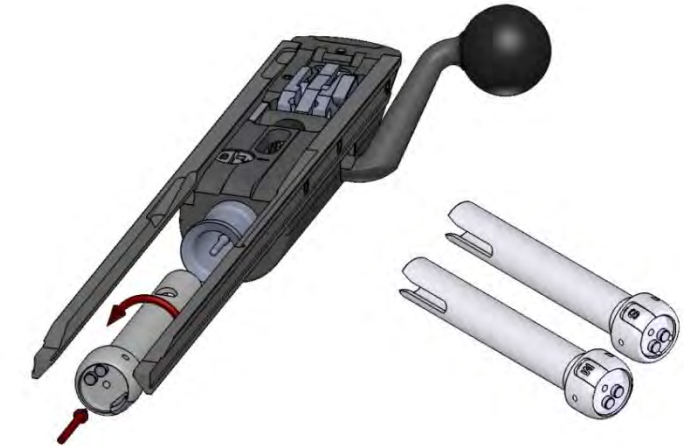

- d. The bolt head has a "fool proof" design which means that you can only assemble it on the bolt shaft when it is in the correct position.
- e. To find the correct position, turn round the bolt head in its housing until you feel that it fits into place, that is when the extractor claw is at a "Five o'clock" position, when looking at the bolt face. (See drawing hereafter)

You are now to replace the bolt -1- in its housing. The bolt head must be in contact with the sleeve. With the handle of your screwdriver, tap gently on the bolt head, so as to make it slip downwards. Once it is in place, you can turn the locking axle -2- one half a turn, placing the padlock symbol opposite the bearing engraved on the bolt shaft.

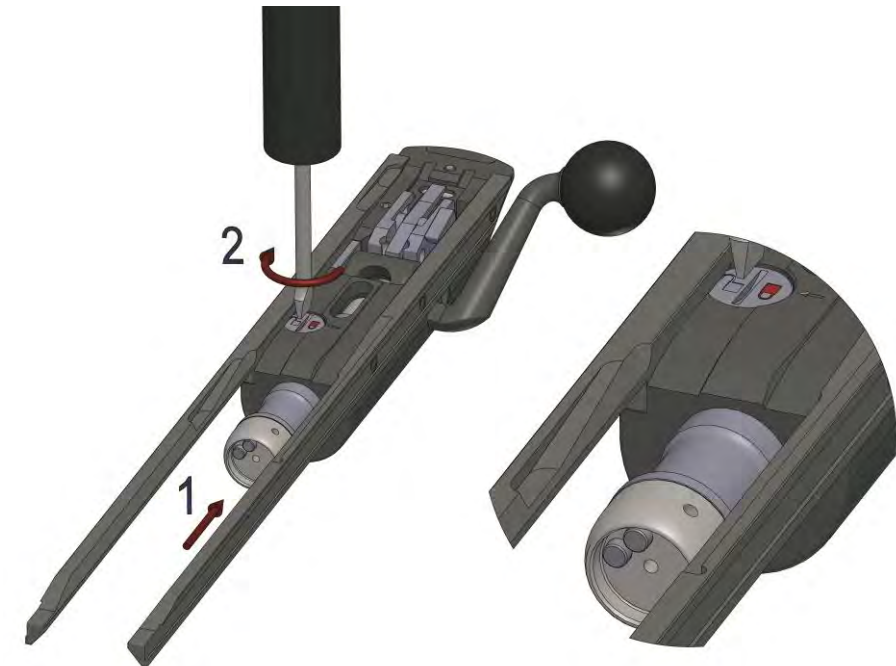

- f. You can now insert the bolt assembly on the receiver. (Refer to § II-2)

WARNING Whenever the locking axle of the bolt head were not completely secured and you still wish to reassemble your bolt on the receiver, then the bolt lever will not close and the bolt will remain open

VII) SCOPE MOUNTS

Locking and un-locking the scope mounts is performed by means of 2 locking lugs on the left side of the scope mounts.

- a) To fix your scope on the barrel, insert both notches on the right side of the mounts into both dovetails machined on the right side of the barrel. Firmly press the mount on the barrel. The central recoil lug will fit into its housing machined on top of the barrel.
- b) The mount is ready to be secured. Turn upwards both locking lugs on the left side of the mount until you hear a "click" which tells that both lugs are firmly locked in place.

WARNING Never shoot with a scope or scope mount which are not properly secured. The recoil could send the scope backwards, possibly injuring the shooter. Apply the usual recommendations pertaining to the use of a scope, such as eye relief distance, proper shouldering, because inappropriate use, or bad habits, could injure the shooter

VIII) CLEANING AND MAINTENING YOUR RIFLE

Maintenance of the rifle should be made according to standard rules, by qualified gunsmiths. Using proper cleaning products sold by gunsmiths can be used. We recommend to follow the instructions concerning the use of such products.

1) Barrel:

WARNING The patented "CLS" locking system of your rifle is a part of the barrel itself. It is located in front of the chamber and CANNOT, in NO circumstances, be removed from the barrel.

In case of problem, refer to our dealer or to an agreed gunsmith.

The outer surface is blued and the barrel is hammer-forged. After shooting it must be thoroughly cleaned with a brush of matching caliber. For the outer surfaces, use gun oil.

2) Receiver and bolt assembly:

Your receiver and bolt shaft have been machined out of a piece of alloy mainly used in aeronautics. This high quality metal was then anodized, a chemical treatment producing different colors: Bronze, Black, Old Silver etc...

After shooting the rifle, the outer parts should be cleaned with a cloth lightly soaked with gun-cleaning products. Never use solvents or rough materials which could damage the surface of the outer parts of the rifle

3) Wooden stock and shaft:

The stock and shaft of your rifle have been manufactured with the greatest care out of selected walnut outlines. Today, they have become so scarce that they are near to turn precious. They have been selected as much for their beauty, color, pattern, as for lack of defaults. Once machined and made smooth, the stocks and shafts are oiled. They must be maintained with proper products.

IX) THE MULTI PURPOSE TOOL

Some of the ROLS Models have been fitted with a multi-purpose tool integrated to an elegant take-down pistol grip cap. The following sketches will show you how to use this multi purpose tool which will give you full autonomy for assembling and disassembling your ROLS rifle :

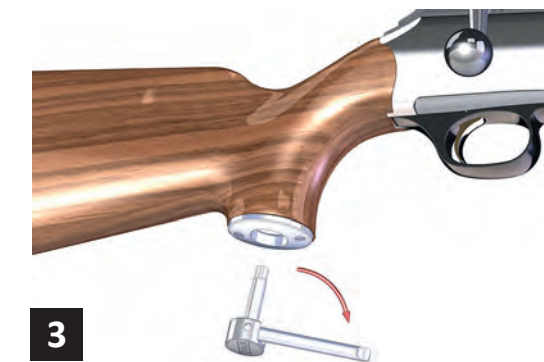
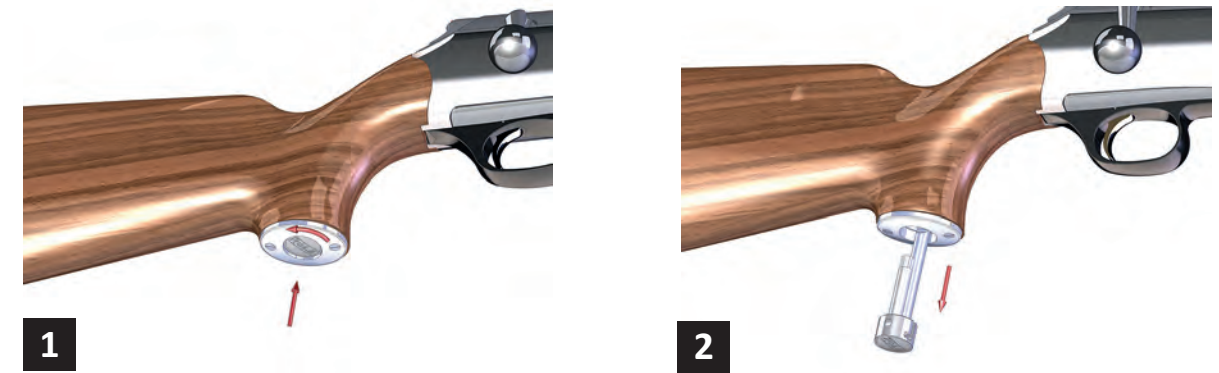

See chapter II page 2



See chapter VI pages 8-9

x) GUARANTEE

The “ Société Chapuis Armes ” extends its guarantee for its rifles for two years after they have been bought, on condition that the guarantee certificate herewith has been duly filled by the buyer and then sent to “Chapuis Armes” within 10 days after being bought.

This guarantee is extended to the first buyer only, living in the country where the rifle has been bought.

All Chapuis Armes guns are proofed under CIP regulations by the Saint-Etienne Proofhouse and wear the corresponding official stamps.

As our barrels have been submitted to the official mandatory proof, the warranty does not cover barrel swelling or ruptures which generally have fortuitous causes such as bore obstructions, etc.

This guarantee applies only to the metal parts of the rifle and to parts made out of plastic which could turn out faulty. Under the terms of this warranty, we shall repair or replace at our choice and solely in our workshops whatever parts that might be found defective, on condition that the damage does not result from normal wear, or from negligence, or spare parts resulting from repairs made by unauthorized persons. Parts made out of wood, a natural material, are excluded from the guarantee.

The rifle should be sent to the “Société Chapuis Armes”, at the expense of the sender, with a copy of the guarantee certificate. It is mandatory to use a proper packing, or if not available, to refer to our dealer or to an authorized gunsmith.

No other warranty, either explicit or implicit, is offered.

WARNING When returning the rifle to the “ Société Chapuis Armes” it is mandatory to check that your rifle is unloaded. Rifle and cartridges must be sent separately and you must follow the national rules pertaining to the sending of firearms.

(Original purchaser’s copy)

Model Calibre

Serial number

Date of purchase Date of warranty expiration

Original seller’s commercial stamp

WARRANTY REGISTRATION CARD

(Original seller’s copy, to be filled out and signed by the purchaser, stamped by the seller and returned to Chapuis Armes within 10 days of purchase)

Model Calibre

Serial number

Date of purchase Date of warranty expiration

Original seller’s commercial stamp

Purchaser’s details

Name

Occupation

Address

Zip cod City

Country Email



ROLS
BY CHAPUIS ARMES

By = Par.



www.chapuis-armes.com

ZI La Gravoux • 42380 St-Bonnet-le-Château
Tél. (33) 04 77 50 06 96 • Fax (33) 04 77 50 10 70
info@chapuis-armes.com



Entreprise
du Patrimoine
Vivant